

Xenon Strobe Beacons Series D

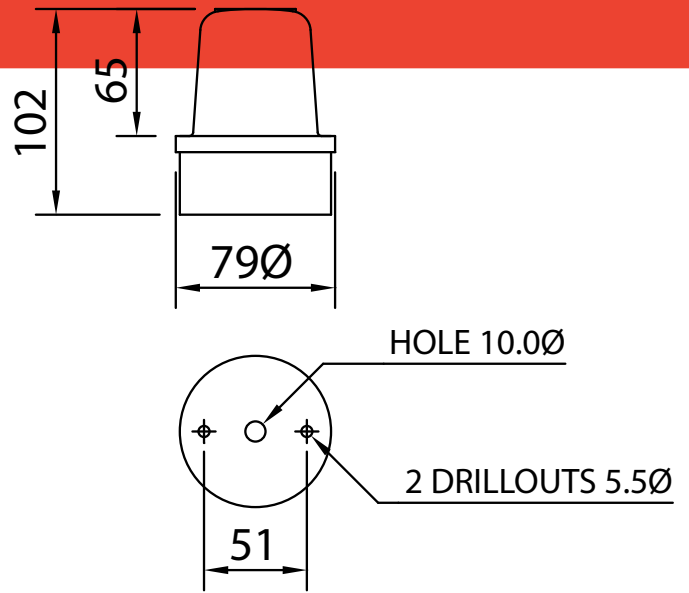

2.5 joule low-energy xenon strobe warning beacons.

Comprising a robust White (standard) or Black (option) ABS Base, and a Polycarbonate lens.

Circuitry is fixed to the base, with convenient access to the terminal block for wiring. Lenses are fitted to the bases by three stainless steel screws and a custom moulded gasket seal.

Supplied as a complete boxed beacon (Base assembly and Coloured dome lens)

	XFD/DC/12-24/SH/2.5J	XFD/AC/115/SH/2.5J	XFD/AC/230/SH/2.5J	
Supply Voltage	12-24Vdc	115Vac	230Vac	
Minimum Supply Voltage	10.2Vdc	97Vac	195Vac	
Maximum Supply Voltage	27.6Vdc	132Vac	264Vac	
Average Current Draw	163mA	68mA	34mA	
Peak Operating Current	482mA	4.4A	4A	
Nominal power consumption	3.9W	3.0W	3.2W	
Flash Rate	60fpm 1Hz			
Luminous Intensity	Red	8cd	6cd	6cd
(Schmidt-Clausen	Amber	23cd	16cd	16cd
Day)	Green	17cd	12cd	12cd
	Blue	10cd	7cd	7cd
	Clear	44cd	30cd	30cd
Angle of max rated brilliance	0 Degrees Vertical			
Recommended fuse rating	External - T500mA			
IEC protection class	IP65			
Operating Temperature Range	-20 to +55 Degrees C			
Net Product Weight	144g	138g	141g	